

Profile Dimensions

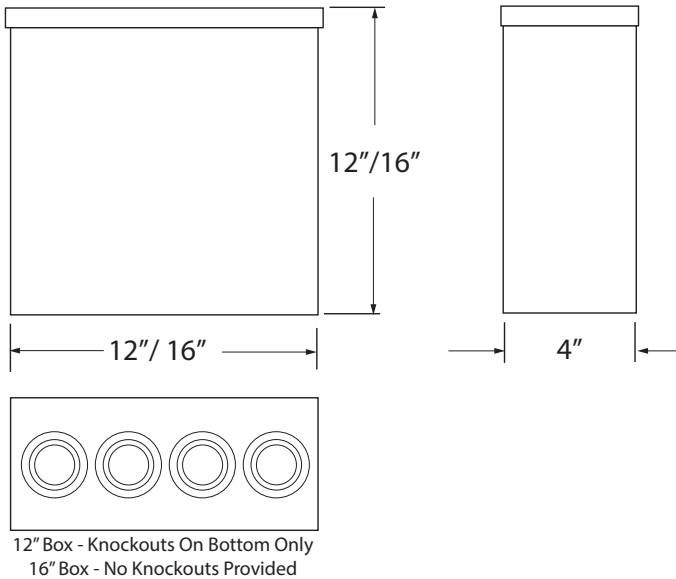

Please verify the contents of the packages!

Please read instructions entirely before starting installation
Be sure power is turned off before installing or modifying the system

Call Tivoli, LLC tech support with questions

Caution: This Power Supply is designed to work on 100-277V AC line voltage only. Use of any other power source will cause damage, shorten the life of the fixture and will void the warranty.

Consult any and all applicable local and national codes for installation.

Do not conceal or extend exposed conductors through a building wall as per local electrical code.

Warning: With any luminaire or power supply for any application, basic safety precautions should always be followed to reduce the risk of fire, electric shock and personal injuries. This power supply should be installed by a certified professional.



Installation Instructions

Mounting Location Requirements

It is recommended that the enclosure be mounted with at least 10" of open space around it for proper ventilation. Do not mount next to or above heat radiating equipment. Operating under high ambient temperature may increase the internal temperature and will require a de-rating in output current. This power supply will operate efficiently between -40° C to +80° C with adequate ventilation. The enclosure is NEMA 3R rated for outdoor/wet applications.

Outdoor Installation

Step 1: Locate Power Supply enclosure (NEMA 3R rated) in a suitable outdoor location.

Step 2: Orient the box in the proper orientation for outdoor use. The solid cover must be positioned at the top to maintain water proof integrity.

Step 3: Note the spacing of the mounting holes when determining mounting location.

Step 4: Knock out access holes as needed. The 12" Box has knockouts along the bottom of the box. The 16" does not include knockouts. Cut out access holes where needed.

Caution! Be careful not to damage internal electrical components.

Step 5: Install strain reliefs (wire clamps) for 1/2" hole size. Input lead wires are 18AWG. Output lead wires are 14AWG.

Input Connection:

Bring external Positive (Black) and Negative (White) Power Lines through Strain Relief on the input side of the Transformer. Connect to Black and White Transformer Leads using the correct size and UL approved Wire Nuts.

Grounding: Connect the Green Ground Wire from inside the enclosure and the Green Transformer wire to incoming ground wire.

Note: The 6" X 8" box has only one Ground Wire.

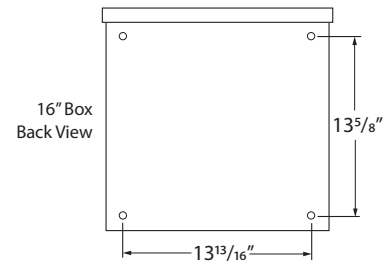
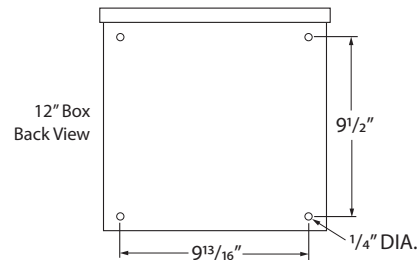
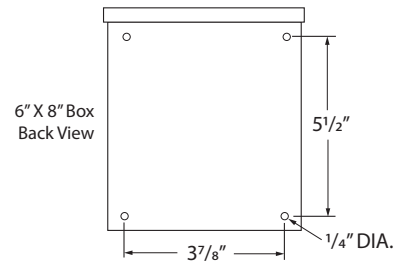

Warnings and Cautions

1. Risk of electrical shock and energy hazard. All failures should be examined by a qualified technician. Do not open the case of the power supply module.

2. Do not install LED power supplies in places with high ambient temperature or close to a fire source.

Luminaire Connections

Connection Options

There are three types of DMX In/Out ports:

1. RJ45
2. 3 Pin XLR
3. Screw connections

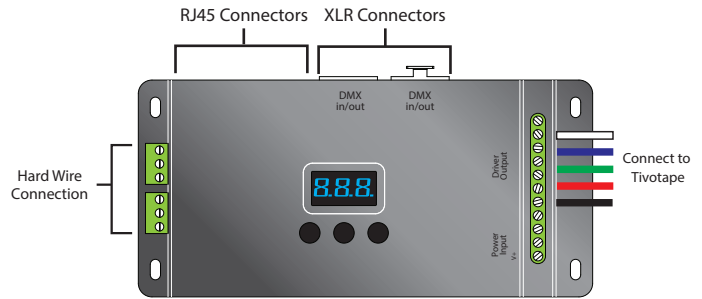

Programming 5 Channel DMX Sub-Controller

Programming the DMX Sub-Controller

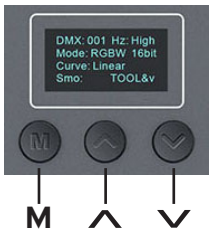

Press "M" key to switch menus.
 Press and hold "M" key to return to main menu.
 Press "^" or "v" Key to make selection.
 Select "Exit" to return to previous Menu.

1. DMX Address Setting

DMX: 001 Hz: High
 Mode: RGB 8bit
 Curve: Standard
 Dim: Smo TOOL&V

Press "^" or "v" key to set DMX address.
 Range: 001-512

Main page

2. PWM Frequency

DMX: 001 Hz: High
 Mode: RGB 8bit
 Curve: Standard
 Dim: Smo TOOL&V

Press "^" or "v" key to choose.

Optional : Std (standard)
 High
 Mid (middle)
 Low

Smooth and delicate, human eye is comfortable. * It is recommended to use standard.
 No flicker in video camera.

3. Mode

DMX: 001 Hz: High
 Mode: RGB 8bit
 Curve: Standard
 Dim: Smo TOOL&V

Press "^" or "v" key to choose.

Optional : Dim / CT
 RGB / RGBW / RGBWY

4. Grey Level

DMX: 001 Hz: High
 Mode: RGB 8bit
 Curve: Standard
 Dim: Smo TOOL&V

Press "^" or "v" key to choose.

Optional : 8bit
 16bit (choose it if the master controller support this function)

5. Dimming Curve

DMX: 001 Hz: High
 Mode: RGB 8bit
 Curve: Standard
 Dim: Smo TOOL&V

Press "^" or "v" key to choose.

Optional : Standard
 Linear
 LOG
 0.1-9.9

It is recommended to use standard, 0.1-9.9 is for special requirements.

6. Enhance Dimming

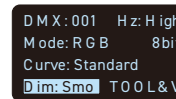

Press "^" or "v" key to choose.

Optional : Std (standard)
 Smo (smooth)

* It is recommended to use standard.

Smo: This option with smooth processing, realize the dimming flicker-free and dynamic effects more downy.

7. Tool

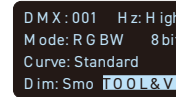

Press "^" or "v" key to enter submenu.

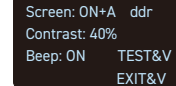

Press "^" or "v" key to enter submenu of test.



Screen: ON+Address
 Screensaver open and display address if undo for 2 minutes.



Screen: ON+black
 Screensaver open and black if undo for 2 minutes.

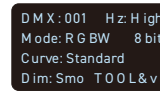

Screen: OFF
 Screensaver not enable.

CH1: 255 CH2: 255
 CH3: 255 CH4: 255
 CH5: 255 ALL: 255
 EXIT & V

Brightness setting (range: 0-255)
 Press "v" to exit

* Fast self-testing function: press "^" or "v" keys simultaneously for 2-3 seconds under any page, decoder will enter self-testing function. The decoder will output full brightness through channels 1 to 5, then activate all channels, and return to the main menu after the auto test. This test is required to verify full operation and functionality of system prior to commissioning.



Tivotape™ RGBW Outdoor Wiring Diagram for 5 Channel DMX Digital Controller

DMX512 & RDM Decoder

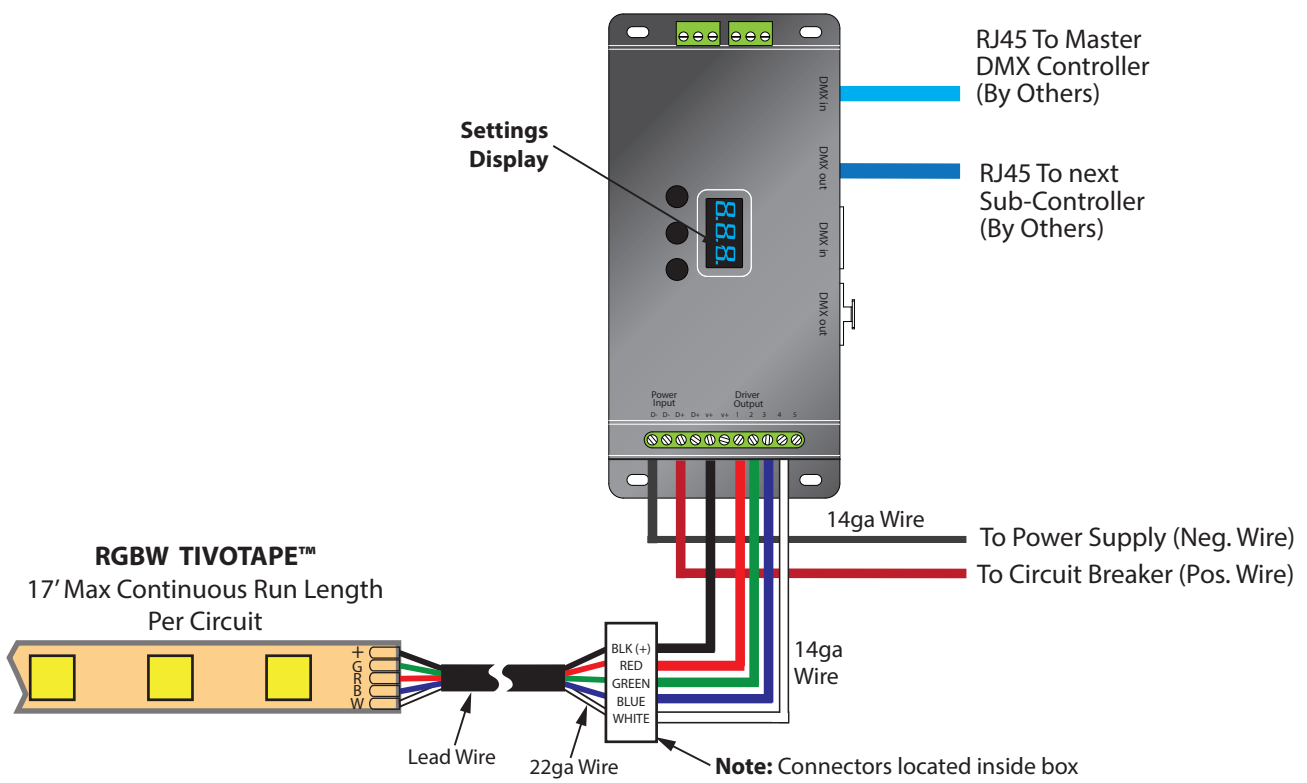
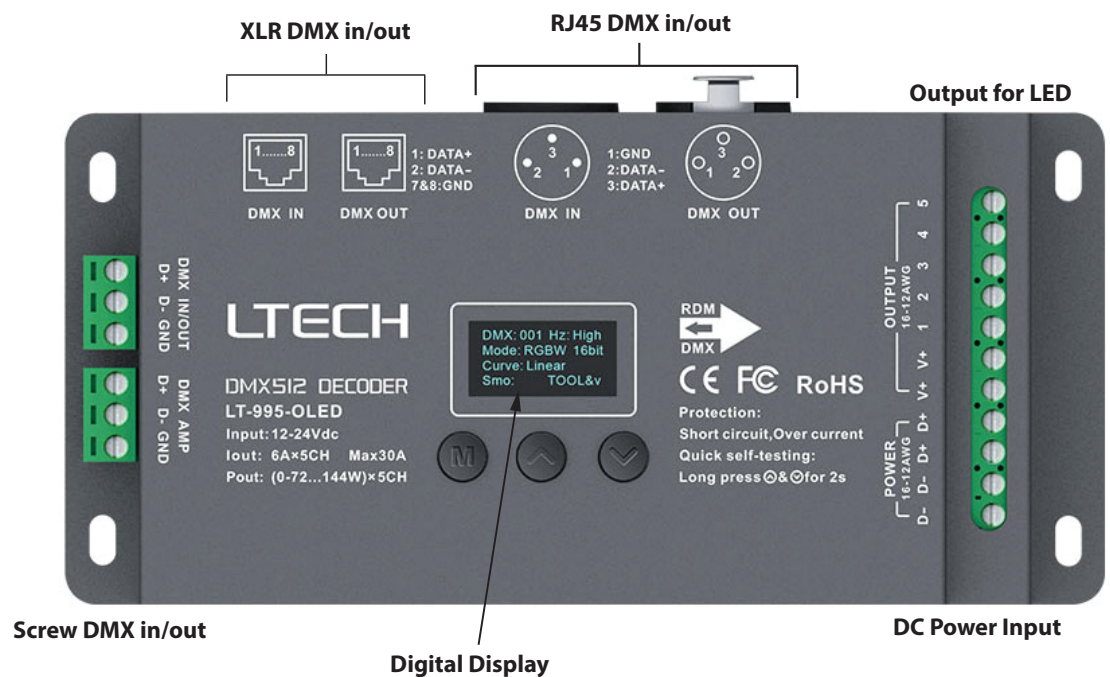

Tivotape™ RGB Outdoor Wiring Diagram for 3 Channel Decoder

Install Transformer Enclosure

Step 1: Locate Transformer enclosure in a suitable indoor or outdoor location. Power supply enclosure is water-tight and may be installed in outdoor wet environments.

Step 2: Connect Transformer input to 100-277V AC line voltage.

Step 3: Connect luminaire to Terminal connector, as shown. Installer is responsible to select the right size wire for run length and total wattage for each circuit. Do not exceed 90 watts per circuit for 24V or 60 watts for 12V.

Note: This Controller is not suitable for RGBW.

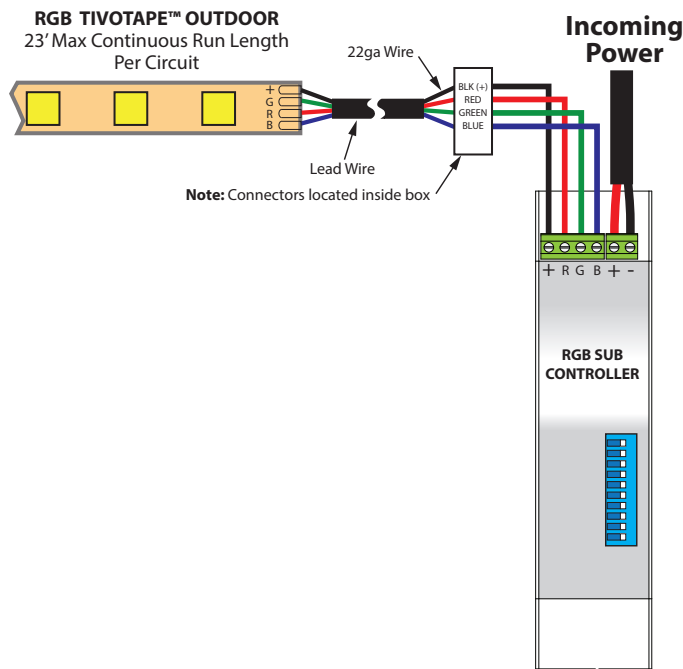

DMX-512 Address Code Setting

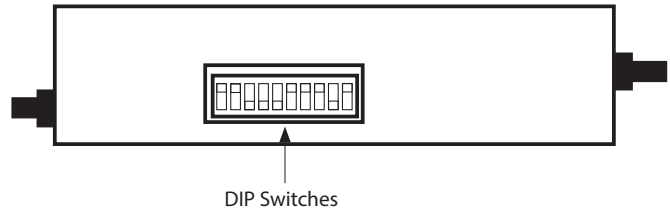

This sub-controller has a total of 512 address codes. 1 represents the least significant byte (LSB) and 9 is most significant byte (MSB). The initial address code is the DMX signal received by Channel 1 of the decoder. Channel 2 will receive data on the initial address code + 1 and Channel 3 will receive data on the initial address code + 2. The initial address code is the sum of DIP switches 1-9 in the "On" position. The 10th switch is not used.

Move a switch up to turn it on and leave it in the down position to achieve a "0" value.

Value of each DIP Switch

DIP	1	2	3	4	5	6	7	8	9
VALUE	1	2	4	8	16	32	64	128	256

Example: Set to 38

Set the 2nd, 3rd and 6th switch to "1" and set the rest to "0". The sum of the switches is 2+4+32 for an address of 38.



Connect RGBW Controller to Sub-Controller

Step 1: Interconnect RGBW controller (DMX512 signal) to Sub-Controller using CAT5 Cable with RJ45 connectors. Refer to the diagram for custom wiring applications. Be sure to maintain correct polarity if custom wiring is required.

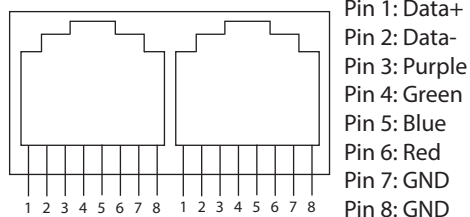

Basic Programming Codes:

RED: 1 off, 2 through 9 on
BLUE: 1 and 2 off, 3 through 9 on
GREEN: 2 off, 1 and 3 through 9 on
WHITE: 3 off, 1, 2 and 4 through 9 on
DMX SIGNAL: 1 on, 2 through 9 off

ADNM-DIN Series Wiring Diagrams

ADNM-320-4-5-12-DIN

100-277V AC / 12V DC, 240W / 4 CIRCUITS X 5A

BOX SIZE:
12" X 12" X 4"
NEMA 3

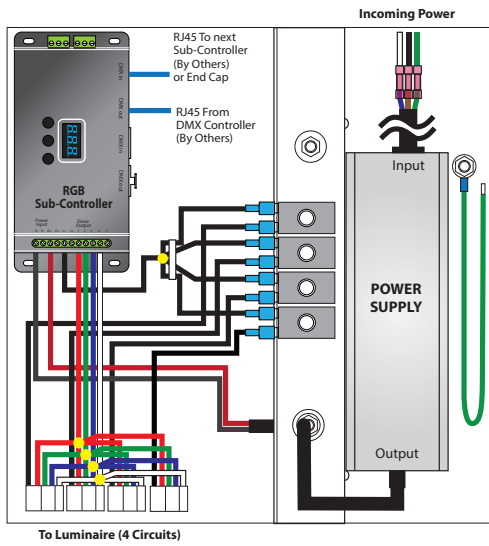

ADNM-240-3-5-12-DIN-3

100-277V AC / 12V DC, 180W / 3 CIRCUITS X 5A

ADNM-320-3-4-24-DIN-3

100-277V AC / 24V DC, 288W / 3 CIRCUITS X 4A

BOX SIZE:
16" X 16" X 4"
NEMA 3

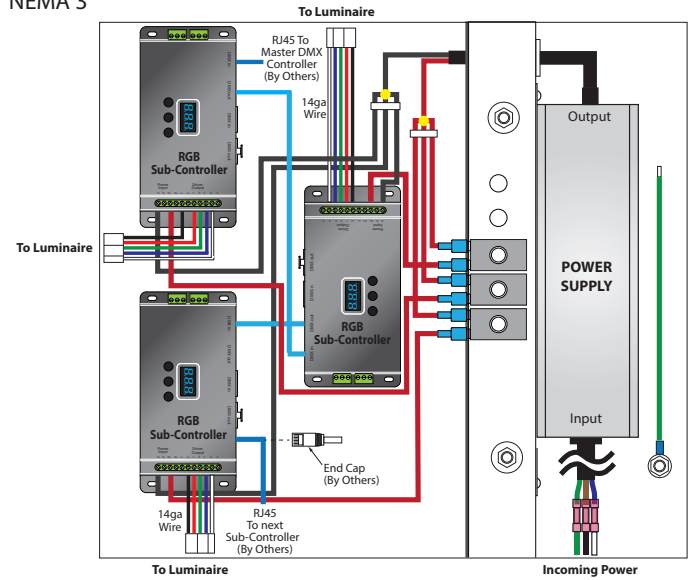

ADNM-240-3-5-12-DIN

100-277V AC / 12V DC, 180W / 3 CIRCUITS X 5A

ADNM-320-3-4-24-DIN

100-277V AC / 24V DC, 288W / 3 CIRCUITS X 4A

BOX SIZE:
12" X 12" X 4"
NEMA 3

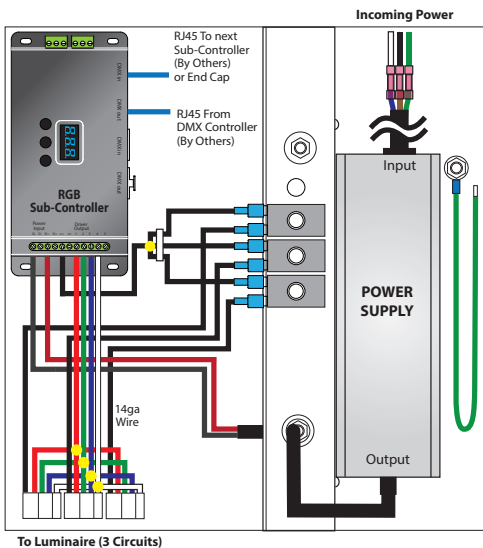

ADNM-150-2-5-12-DIN-2

100-277V AC / 12V DC, 120W / 2 CIRCUITS X 5A

ADNM-240-2-4-24-DIN-2

100-277V AC / 24V DC, 192W / 2 CIRCUITS X 4A

BOX SIZE:
12" X 12" X 4"
NEMA 3

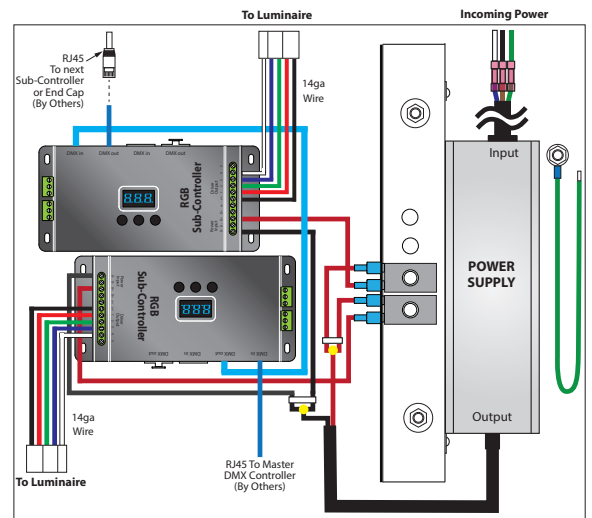

ADNM-DIN Series Wiring Diagrams

ADNM-150-2-5-12-DIN

100-277V AC / 12V DC, 120W / 2 CIRCUITS X 5A

ADNM-240-2-4-24-DIN

100-277V AC / 24V DC, 192W / 2 CIRCUITS X 4A

BOX SIZE:
12" X 12" X 4"
NEMA 3

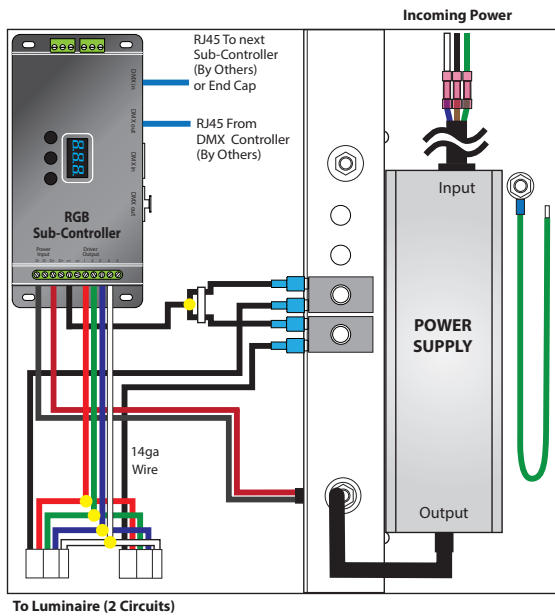

ADNM-80-1-5-12-DIN

100-277V AC / 12V DC, 60W / 1 CIRCUIT X 5A

ADNM-120-1-4-24-DIN

100-277V AC / 24V DC, 96W / 1 CIRCUIT X 4A

BOX SIZE:
12" X 12" X 4"
NEMA 3

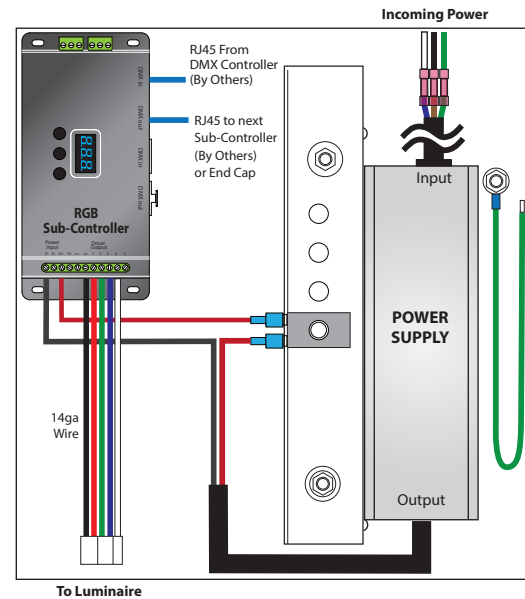

ADNM-60-1-5-12-DIN*

100-277V AC / 12V DC, 60W / 1 CIRCUIT X 5A

ADNM-90-1-4-24-DIN*

100-277V AC / 24V DC, 90W / 1 CIRCUIT X 4A

*Not suitable for RGBW

BOX SIZE:
6" X 8" X 4"
NEMA 3

