

# MARSALA

Design Guide

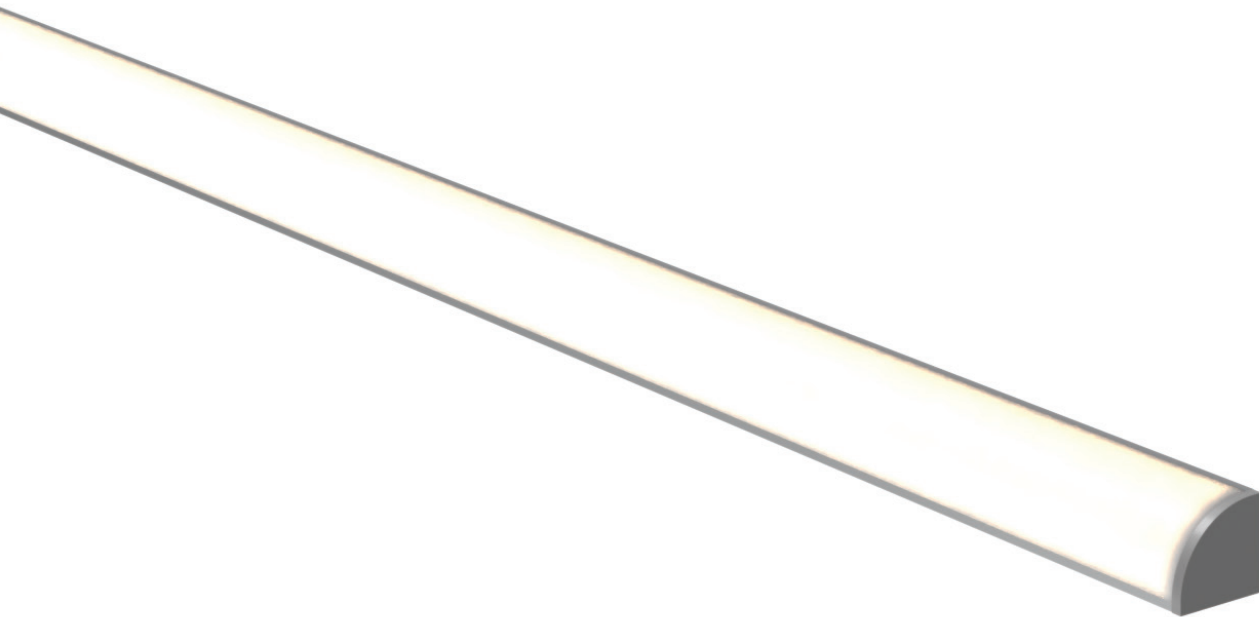

Profile & Dimensions

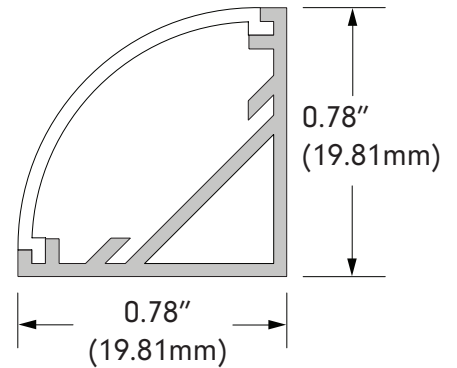
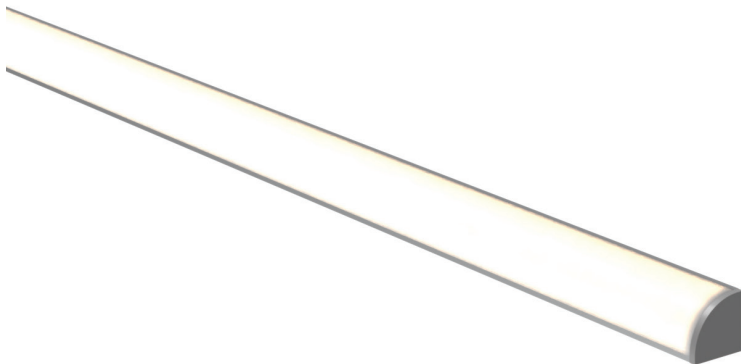

Available TivoTape Options - Indoor

**DEFINE**  
LB  
SB  
HO

**ELITE**  
SB  
HO  
VHO

**ELITE+**  
Standard  
Pro  
Vision  
Flow

**FUSE24**  
RGB  
RGBW

**FUSE12**  
PiXEL RGB

Ordering Information

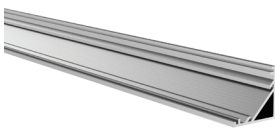

**MRSL-CHAN-SLV-6.5**  
Silver Anodized Aluminum  
Extrusion, 6.5' Lengths



**MRSL-LNS-XXX-6.5**  
**XXX = OPL** (Opal), **CLR**  
(Clear), **DIF** (Diffused)  
Round lens, length 6.5'



**MRSL-LNS-SQ-XXX-6.5**  
**XXX = OPL** (Opal), **CLR**  
(Clear), **DIF** (Diffused)  
Square lens, length 6.5'



**MRSL-CLP-SLV**  
Clip, Silver



**MRSL-EC-01**  
Solid End Cap



**MRSL-EC-02**  
Powerfeed End Cap

Photometrics

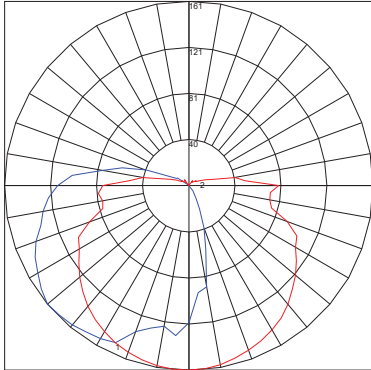

MARSALA WITH CLEAR LENS  
Lumens per foot: 435.52  
Watts per foot: 4  
CRI : 95.1  
Peak Candela: 119.82

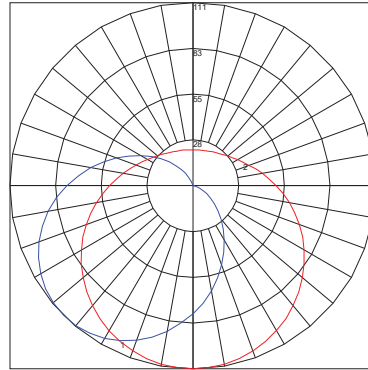

MARSALA WITH DIFFUSED LENS  
Lumens per foot: 359.48  
Watts per foot: 4  
CRI : 95.7  
Peak Candela: 110.98

Diode Visibility



Opal lens



Clear lens



Diffused lens

